

WLA1216A

1.2 – 1.6 GHz, Low Noise Amplifier

April 2013, REV B



Key Features

- 1.2 ~ 1.6 GHz, 50 Ohm impedance
- 0.9 dB noise figure
- 17 dB gain
- 1.35:1 VSWR
- 15 dBm P_{1dB}
- Precision machined housing
- RoHS compliant

Applications

- GPS
- Receiver amplifiers
- RF bench tests
- Mobile base station applications



Absolute Maximum Ratings

Input CW RF Power	10 dBm
DC Voltage, V _{dd}	-0.5, +32V
Operating Temperature	-40°C to +85°C
Storage Temperature	-40°C to +85°C

Functional Block Diagram

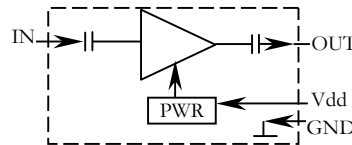

Ordering Information

Model	Connectors
WLA1216A	SMA Female

Marking: WLA1216A

Specifications (Tested at +25°C)

tem	Symbol	Test Constraints	Min	Nom	Max	Unit
Frequency Range	BW	50 Ohm Impedance	1.2		1.6	GHz
Gain	S ₂₁	1.2 – 1.6 GHz	16	17	18	dB
Noise Figure	NF	1.2 – 1.6 GHz		0.9	1.2	dB
VSWR	SWR _i	1.2 – 1.6 GHz, all RF ports		1.35:1	1.6:1	Ratio
Gain Flatness	ΔG	1.2 – 1.6 GHz		+/- 0.2		dB
Reverse Isolation	S ₁₂	1.2 – 1.6 GHz		25		dB
Output Power 1dB Compression Point	P _{1dB}	1.2 – 1.6 GHz	12	15		dBm
Output-Third-Order Interception point	IP ₃	Two-Tone, P _{out} = 0 dBm each, 1 MHz separation	26	29		dBm
Current Consumption	I _{dd}	V _{dd} = +12.0 V		35		mA
Power Supply Operating Voltage	V _{dd}		+8	+12	+16	V
Operating Temperature	T _o		-40		+85	°C
Thermal Resistance	R _{th,c}	Junction to case			215	°C/W

Typical Performance

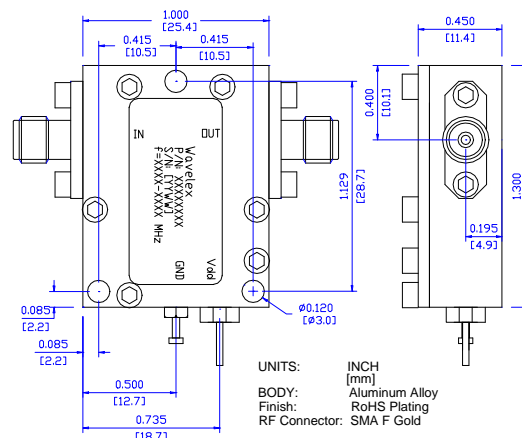
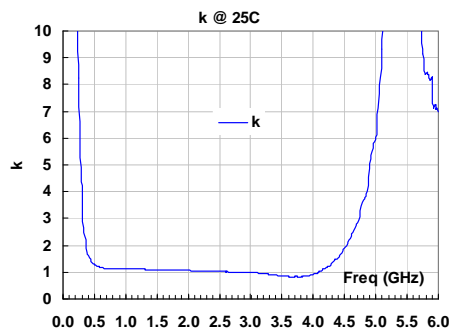
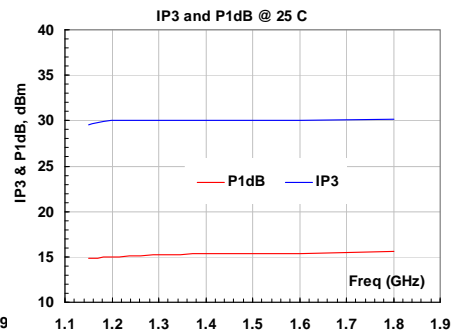
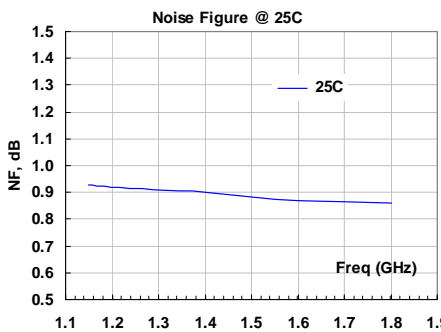
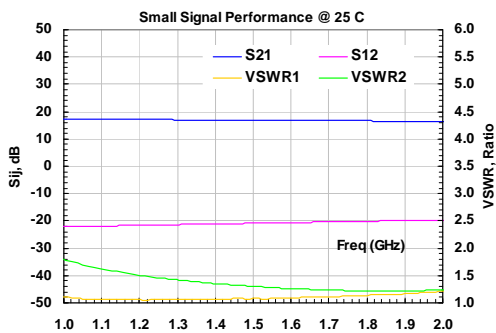

Outline, IP-3

Specifications and information are subject to change without notice.